

Kathrein offers the most comprehensive UHF RFID antenna portfolio. For applications in the read range up to 200 cm, the Mid Range antennas are available for such application.

The MiRa antennas has been developed for applications in the read range between the near and far field. The compact design is perfect for integration in space-critical applications. The antenna can also be excellently used in machines or in metallic installation spaces. As a very robust variant the S-MiRa antenna can be used. Here, the influences of metal are reduced, and the reading range is still up to 100 cm.

The antenna can be used both indoors with droplet formation and spray mist, as well as outdoors with all environmental influences.



> Features

- Integration possible in applications where space is limited
- Wide-open 100° reading zone
- very robust against influence of metal (S-MiRa)
- circular polarisation with very good axial ratio
- ideal for near-field/far-field applications up to 200 cm
- small and robust design
- high IP67 degree of protection
- suitable for outdoor use
- available for Europe, US and RoW

> Key Applications

- Logistics
 - for the registration of containers
 - for personnel registration at access doors
- Industrial automation
 - for detection on conveyor belts
 - for use on industrial vehicles

> Dimensions [mm]

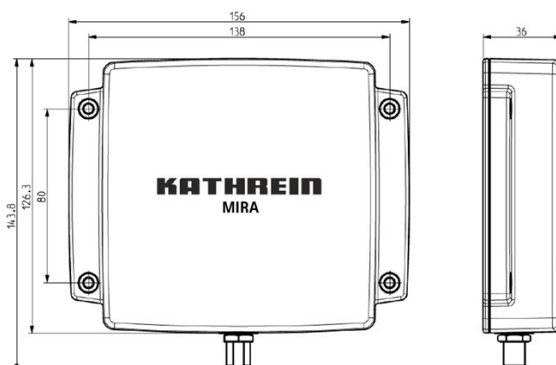

Note

The dimensions for MiRa and S-MiRa antennas are identical.

Risk of material damage!

- ▶ Please ensure that the underlying surface is clean, load-bearing and free of conductors.
- ▶ To mount the antenna, please use four M4 screws

> General Specifications

Type		ETSI Version MiRa	FCC Version MiRa	ETSI/FCC Version S-MiRa
Order number		52010082	52010083	52010172
RFID				
Frequency range	[MHz]	865–868	902–928	865–928
Impedance antenna port	[Ohm]	50		
Antenna gain	[dBic]	2.5 @866 MHz	2.5 @915 MHz	-12 @866 MHz -10 @915 MHz
Far field half-power beam width	[°]	100		
Polarization		circular		
Axial ratio	[dB]	typ. 2		
Front-to-back ratio	[dB]	10		
Max. input power (at antenna port)	[dBm]	-	+30 (FCC 15.247)	+30 (ETSI EN 302 208)
Max. radiated power	[dBm]	+30ERP (ETSI EN 302 208)	-	
Max read range	[cm]	200		100
VSWR		typ. 1.3:1	typ. 1.5:1	typ. 1.4:1
Mechanic properties				
Connection	[°C]	TNC female		
Weight	[kg]	0.32		
Degree of protection	[W]	IP67		
Operating temperature range	[°C]	-20 to +55		
Storage temperature range	[°C]	-40 to +85		
Dimensions (L x W x H)	[mm]	126.3 x 156 x 36		
Packing size (L x W x H)	[mm]	165 x 250 x 50		
Housing material		weather-resistant polymer blend, colour: RAL7045		

> Mounting with MK-WPM3-OSS

Due to the almost spherical reading zone (2m, 100°), there is usually no need to align the MIRA antennas and they can be mounted flat on the ground. However, if it is necessary to align the antennas, the mounting kit 52010351 can be used.

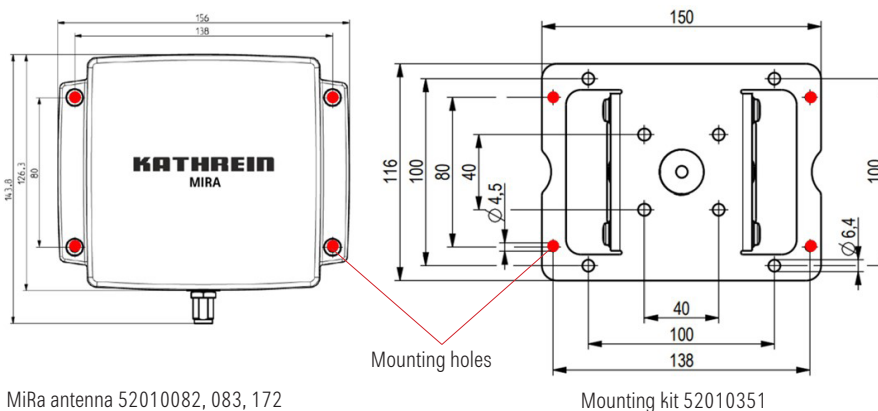

MiRa antenna 52010082, 083, 172

Mounting kit 52010351